

## INDUSTRY NEWS

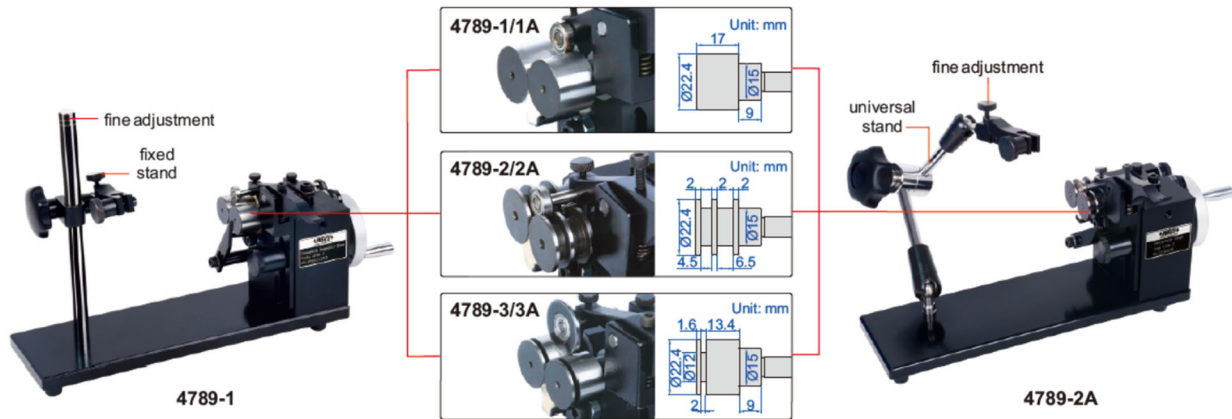

Your Measuring Instrument Source!

### Concentricity Gages



to ensure the accuracy  $2\mu\text{m}$ , the distance between measuring point and roller should be  $<30\text{mm}$

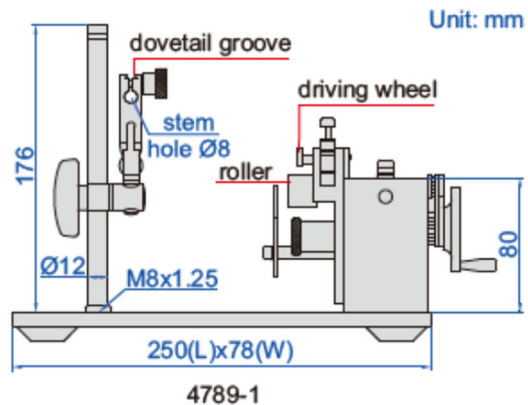
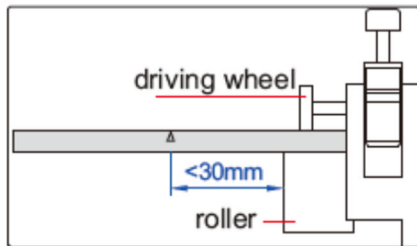

- Accuracy  $2\mu\text{m}$
- Optional accessory: Dial Test Indicator

Code	Applicable diameter	Remark
4789-1	Ø3.5mm-25mm	fixed stand, high accuracy, inconvenient operation
4789-2	Ø1mm-25mm	fixed stand, high accuracy, inconvenient operation
4789-3	Ø1mm-25mm	fixed stand, high accuracy, inconvenient operation
4789-1A	Ø3.5mm-25mm	universal stand, low accuracy, convenient operation
4789-2A	Ø1mm-25mm	universal stand, low accuracy, convenient operation
4789-3A	Ø1mm-25mm	universal stand, low accuracy, convenient operation